

Foredom 230V Foot Control Trigger Switch Replacement

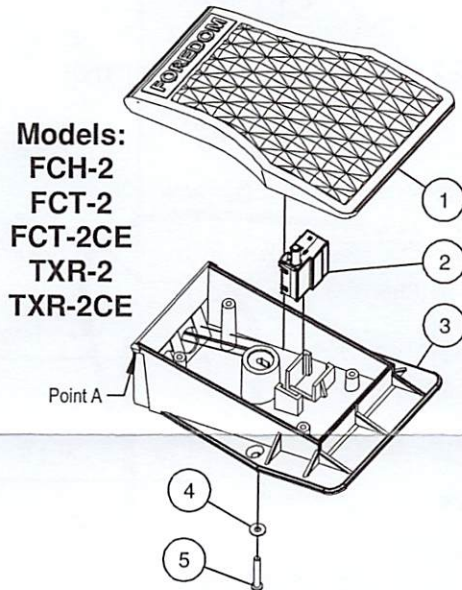

Models:
FCH-2
FCT-2
FCT-2CE
TXR-2
TXR-2CE

Instructions for Removing and Replacing Trigger Switch

Disconnect Foot Control from Motor and Wall Outlet.

1. Unscrew cover adjustment screw (5).
2. Using flat blade of screwdriver inserted at Point A between Cover (1) and Base (3), carefully pry Cover off.
3. Remove Trigger Switch (2) from Base mounting bracket.
4. On older Switches, all the terminals will be push-in, spring clamp type. On newer Switches, some terminals have screw fasteners. To remove wires from the push-in terminals, insert 1.3mm [.05in] approximate diameter pin or the blade of a jeweler's screwdriver all the way into the terminal socket to release the spring clamp. Grasp the tool and wire and pull them together out of the socket. If you have difficulty removing the wires from the push-in terminals and you have wire-cutting, stripping, and soldering tools, you can cut the wires off where they exit from the terminals. To prepare the cut wires for installation into the replacement Switch, strip them back exactly 8.25 mm [5/16 in], then apply solder to the stripped ends to fuse the strands together.
5. **Connect Wires to New Trigger Switch as shown in appropriate Diagram on opposite side.** On the screw terminals, push the wire all the way into the socket and tighten the screw firmly. Push the other wire leads into the designated terminals. Push wires all the way in, so that no bare wire is exposed. Retighten the screw terminals. Pull on all the wires, making sure they are secure. Place Switch back into Base mounting bracket.
6. Position wires around adjustment screw post so wires will not interfere with cover travel.
7. Snap cover (1) onto hinge posts on top of rear corners of base (3).
8. Insert adjustment screw (5) through washer (4) and into post slot and threaded insert in cover (1). Tighten with screwdriver until cover is just touching the trigger switch pushrod. **Do not tighten the screw further** to avoid pressing the Switch Pushrod into a permanently "on" position.

Foredom 230V Foot Control Trigger Switch Replacement

Pg 1 of 2

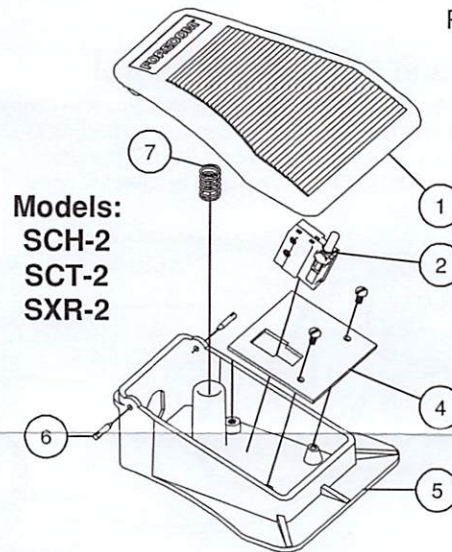

Models:
SCH-2
SCT-2
SXR-2

Instructions for Removing and Replacing Trigger Switch

Disconnect Foot Control from Motor and Wall Outlet.

1. With a punch and hammer drive two Pins (6) in until Cover (1) lifts from each side of Base (5).
2. Remove Cover and drive Pins outward with hammer and punch to remove.
3. Remove two Screws (3) from Board (4). After the wires have been removed from the switch, as instructed in paragraph 4, remove the switch from the board, insert the new switch in its place, and follow the instructions in paragraph 5 and 6.
4. On older Switches, all the terminals will be push-in, spring clamp type. On newer Switches, Terminal 1 has a screw for fastening the wire lead. To remove wires from the push-in terminals, insert 1.3mm [.05in] approximate diameter pin or the blade of a jeweler's screwdriver all the way into the terminal socket to release the spring clamp. Grasp the tool and wire and pull them together out of the socket. If you have difficulty removing the wires from the push-in terminals and you have wire-cutting, stripping, and soldering tools, you can cut the wires off where they exit from the terminals. To prepare the cut wires for installation into the replacement Switch, strip them back exactly 8.25 mm [5/16 in], then apply solder to the stripped ends to fuse the strands together.
5. Insert new Trigger Switch into Board.
6. **Connect Wires to New Trigger Switch as shown in appropriate Diagram on opposite side.** Push the wire lead that goes into terminal 1 all the way into the socket and tighten the screw firmly. Push the other wire leads into the designated terminals. Push wires all the way in, so that no bare wire is exposed. Retighten the screw on terminal 1. Pull on all the wires, making sure they are secure.
7. Install Board and Switch into Base using two Screws (3).
8. Position wires around post of Base so wires will not interfere with Cover travel.
9. Install Cover over Spring (7) and align holes to Base. Insert Pins (6) and seat them with hammer.

FOREDOM[®] Foredom Electric Company
16 Stony Hill Rd., Bethel, CT 06801 • 203-792-8622
Fax: 203-796-7861 • www.foredom.net

DN 10/16

Foredom 230V Foot Control Wiring Diagrams

230 Volt Variable Speed Trigger Switch CP11027

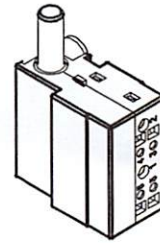

FCT-2 and FCH-2 Foot Control

Most Foot Controls have BLU(WHT) wires connected by a Wire Connector as shown. Leave them connected, and connect only the BRN(BLK) wires to Terminals 1 and 6 on the new Trigger Switch. Otherwise connect all four wires to the Switch as indicated by the dotted wires.

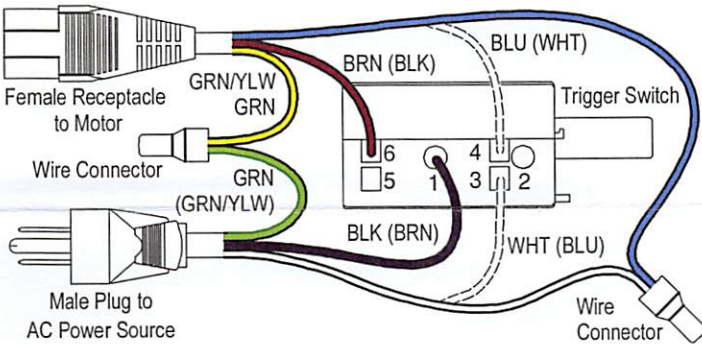

SCT-2 and SCH-2 Foot Control

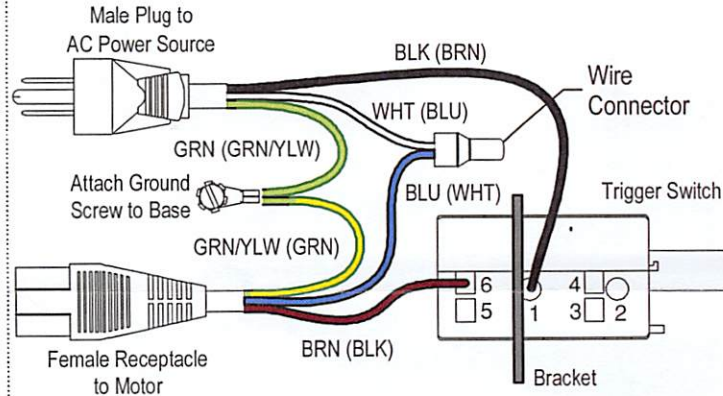

FCT-2CE Foot Control with Single Pole Terminal Block

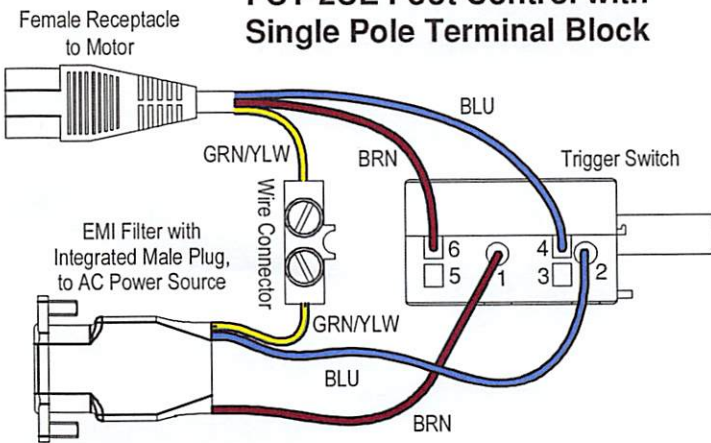

FCT-2CE Foot Control with 4 Pole Terminal Block

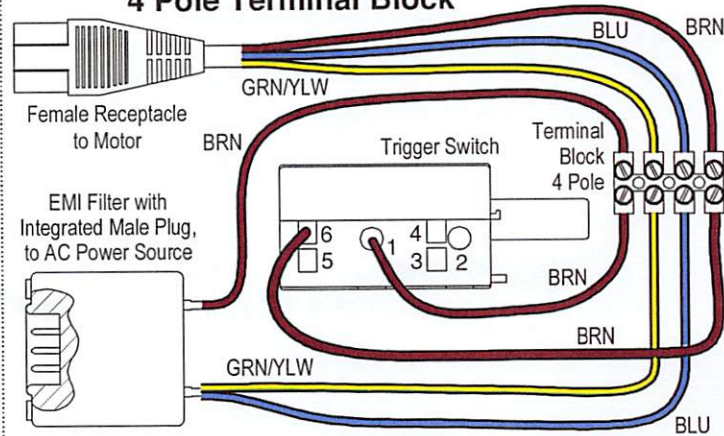

TXR-2 and TXR-2CE Foot Control

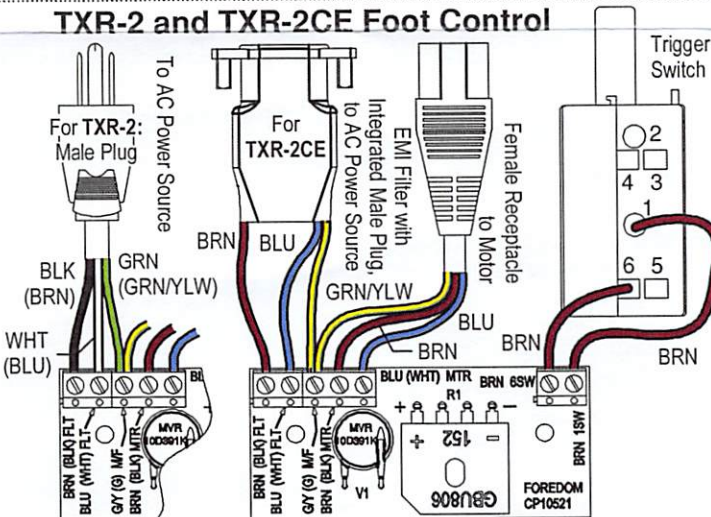

SxR-2 Foot Control

